

PROGRAMMA ACCESSORI
ACCESSORIES PROGRAM
PROGRAMME DU ACCESSOIRES
ZUBEHÖR PROGRAMM
PROGRAMA ACESORIOS
ЛИНИЯ АКССЕСУАРОВ
ΠΡΟΓΡΑΜΜΑ ΕΞΑΡΤΗΜΑΤΩΝ
浴室产品配件

Art. 56781

Art. 67582

Art. 56782

Art. 67583

Art. 67081

Art. 67584

Art. 67082

Art. 67681

Art. 67083

Art. 67682

Art. 67084

Art. 67683

Art. 67581

Art. 67684

GESSI THE
PRIVATE
WELLNESS
COMPANY®



GESSI SpA
Parco Gessi - 13037 Serravalle Sesia
(Vercelli) ITALY
Tel. +39 0163 454111
Fax +39 0163 459273
www.gessi.com - gessi@gessi.it

ART. 56781

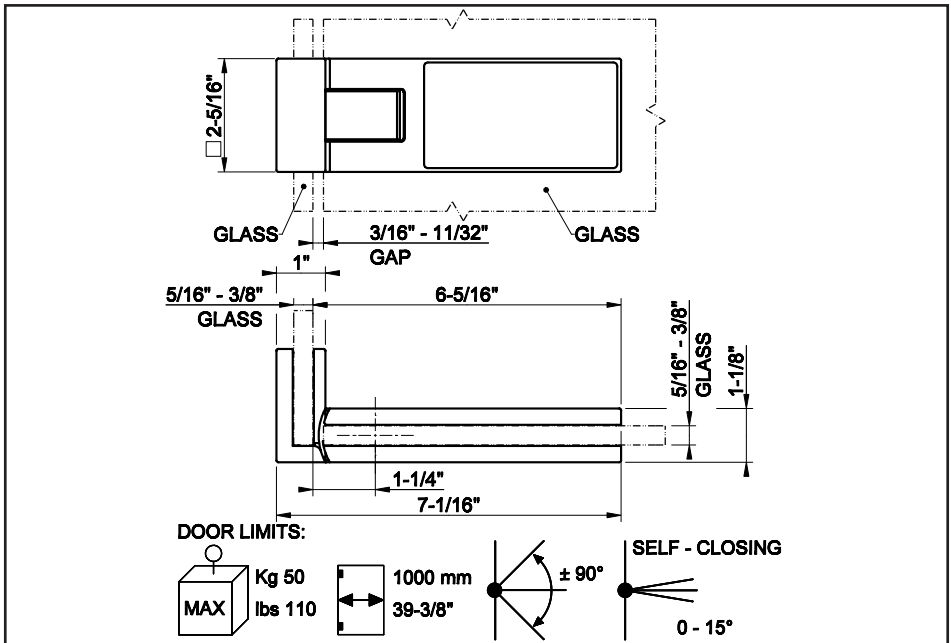
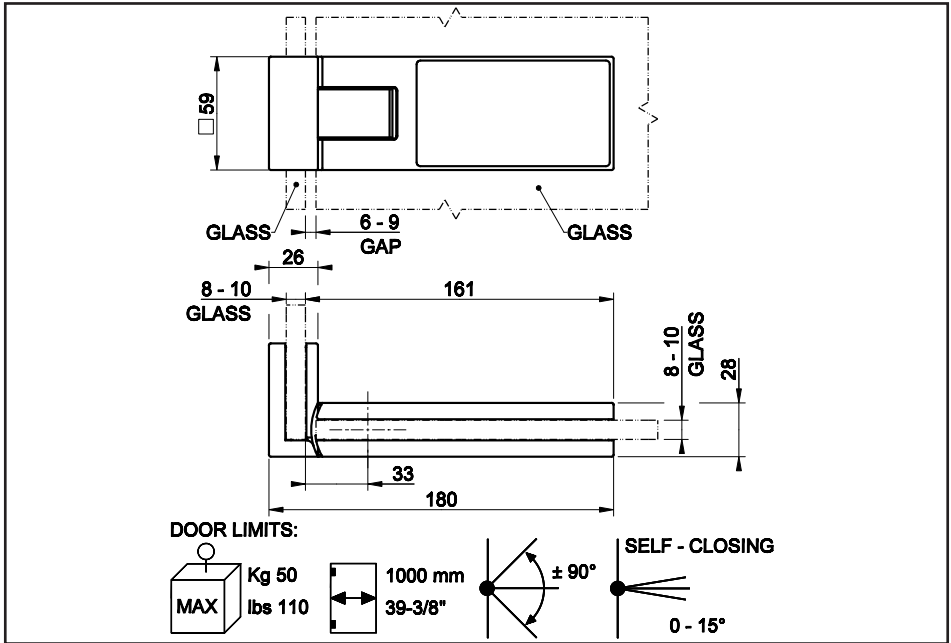

ART. 56782

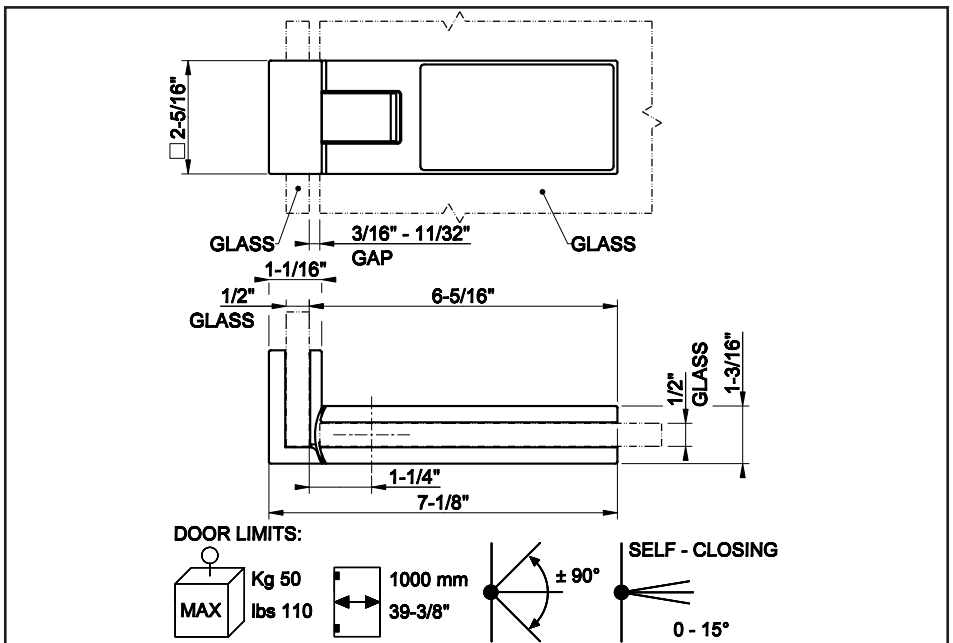
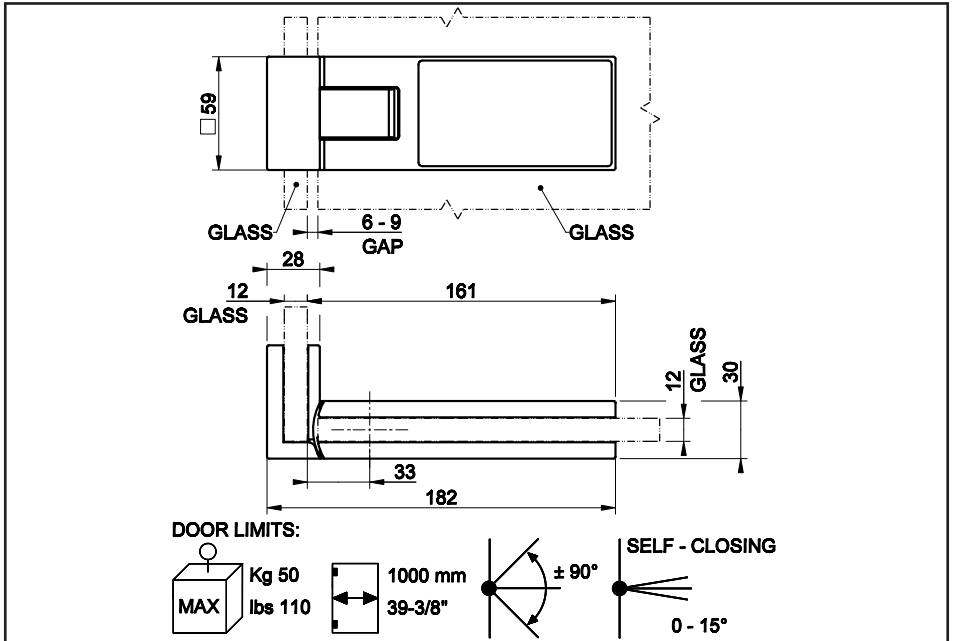

ART. 67081-67581-67681

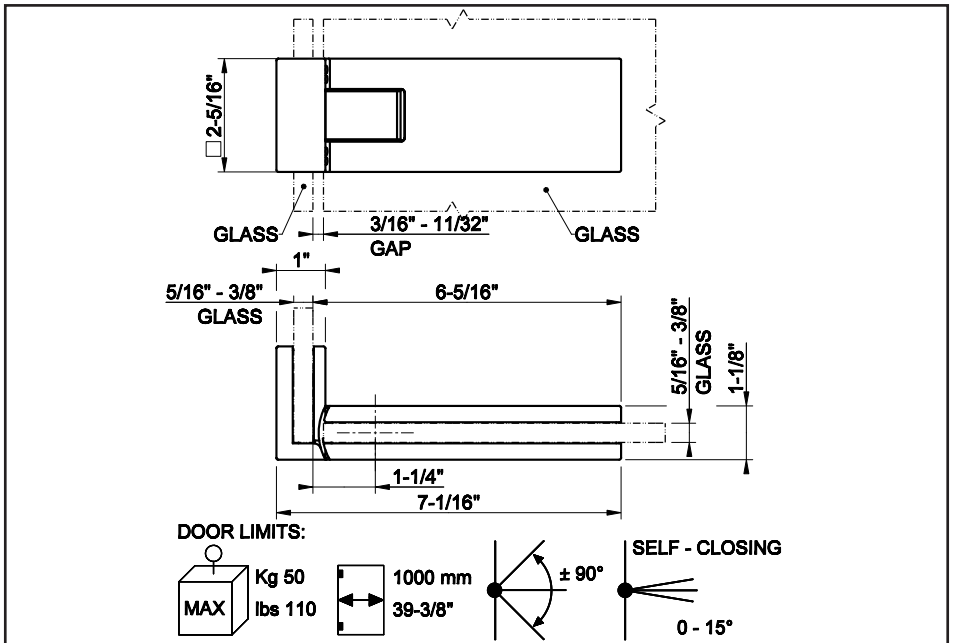
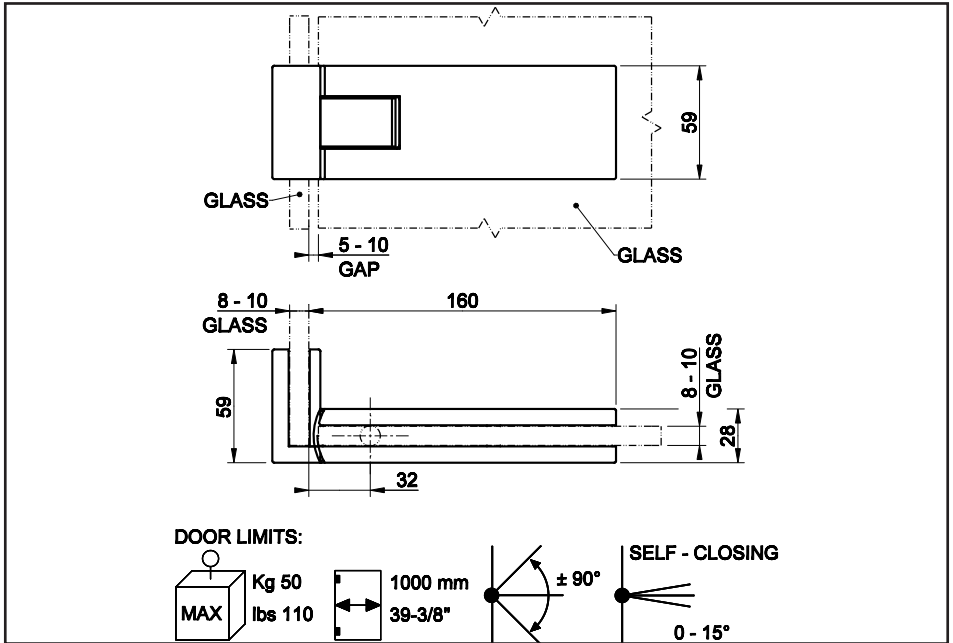

ART. 67082-67582-67682

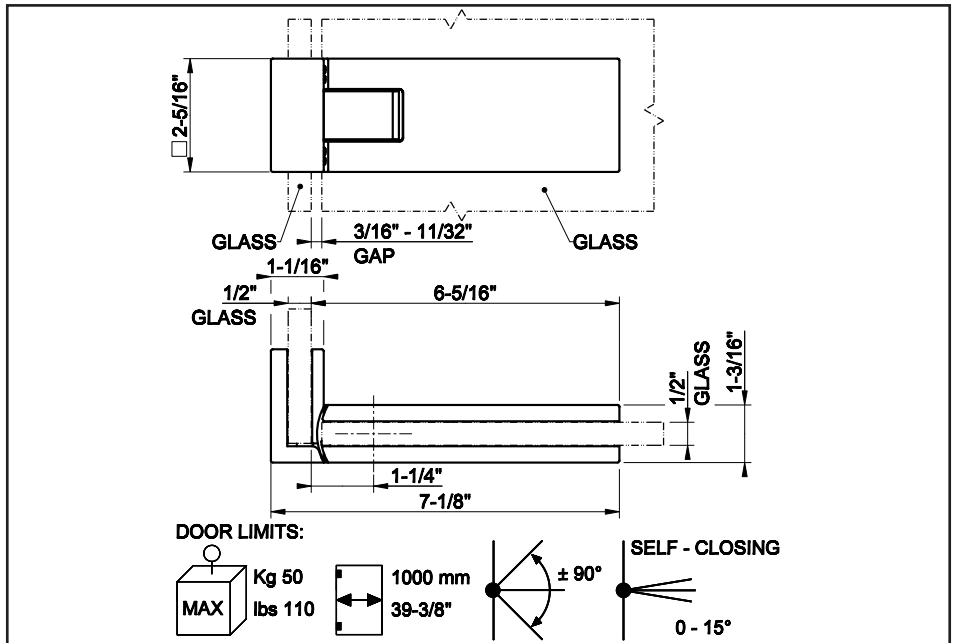
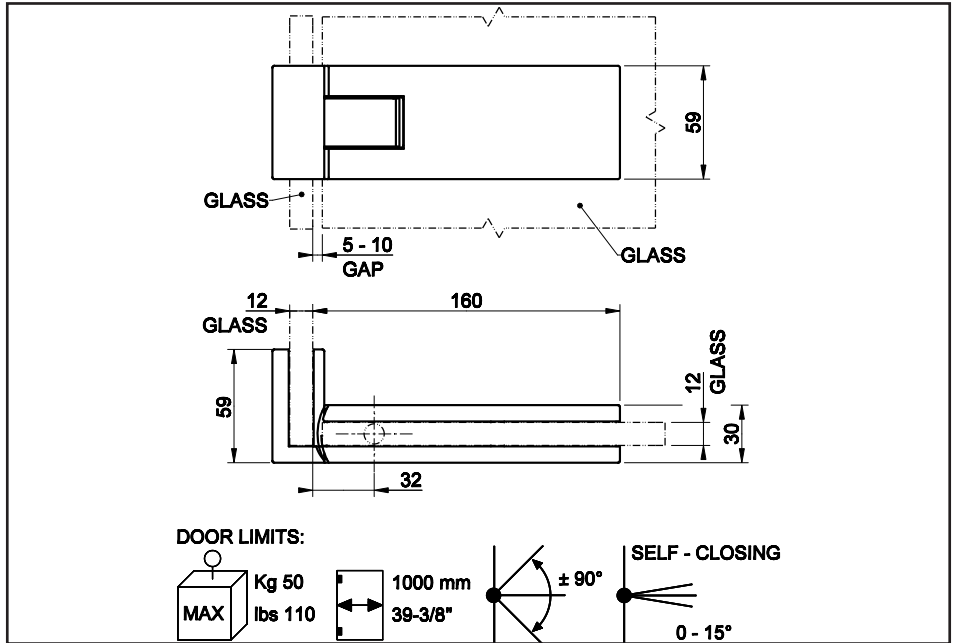

ART. 67083-67583-67683

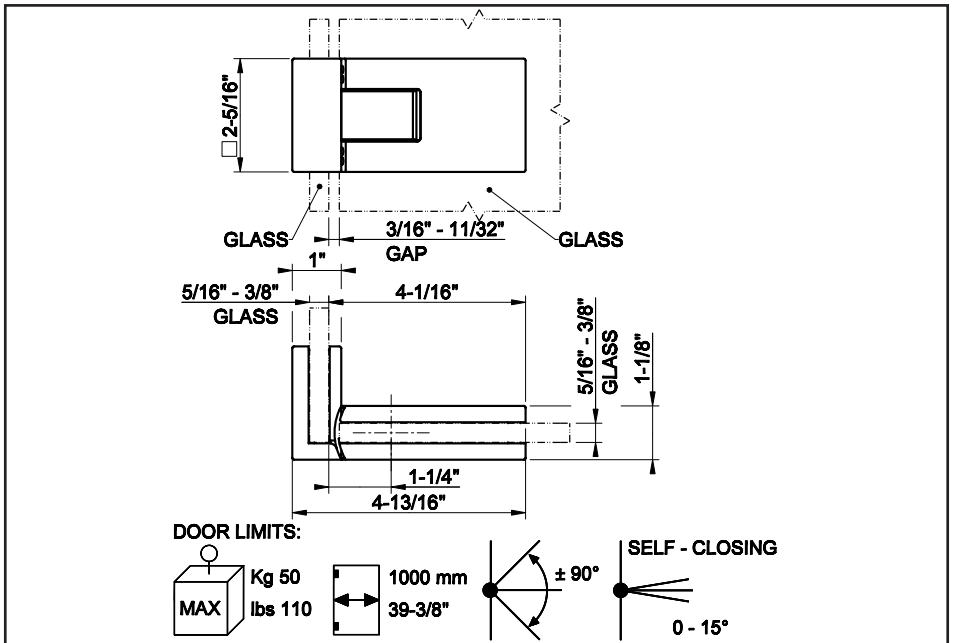
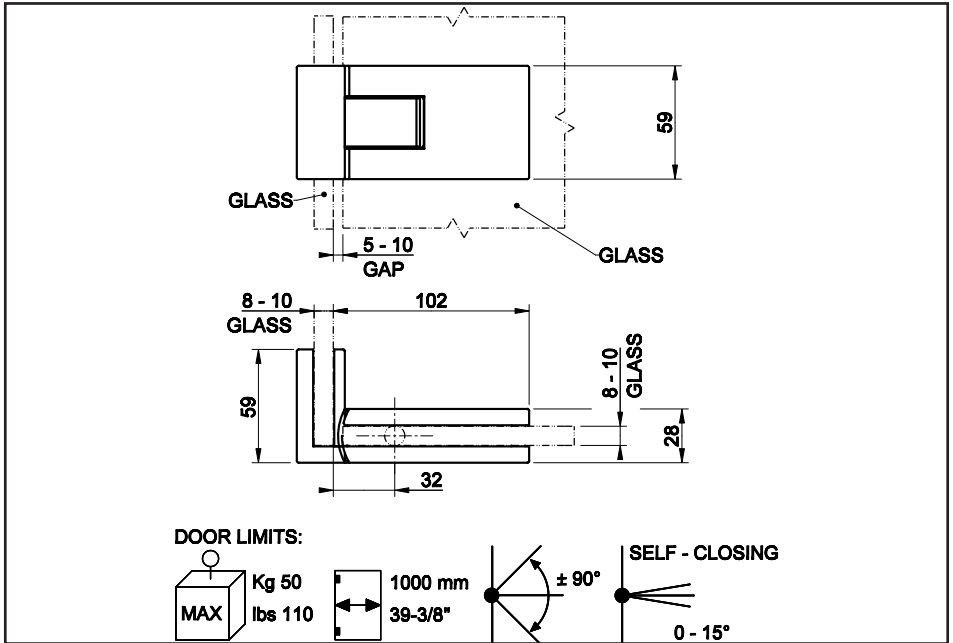

ART. 67084-67584-67684

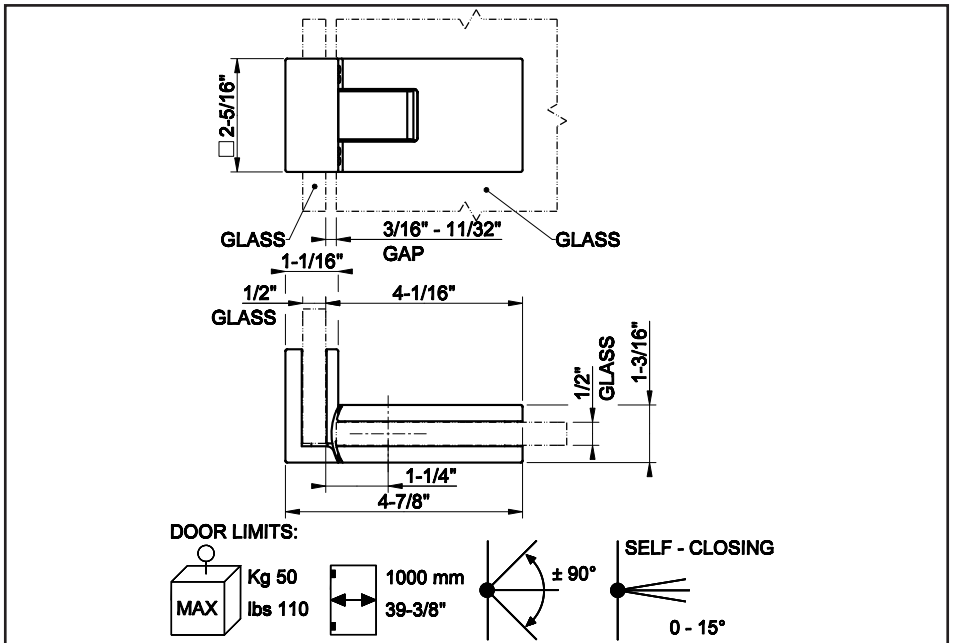
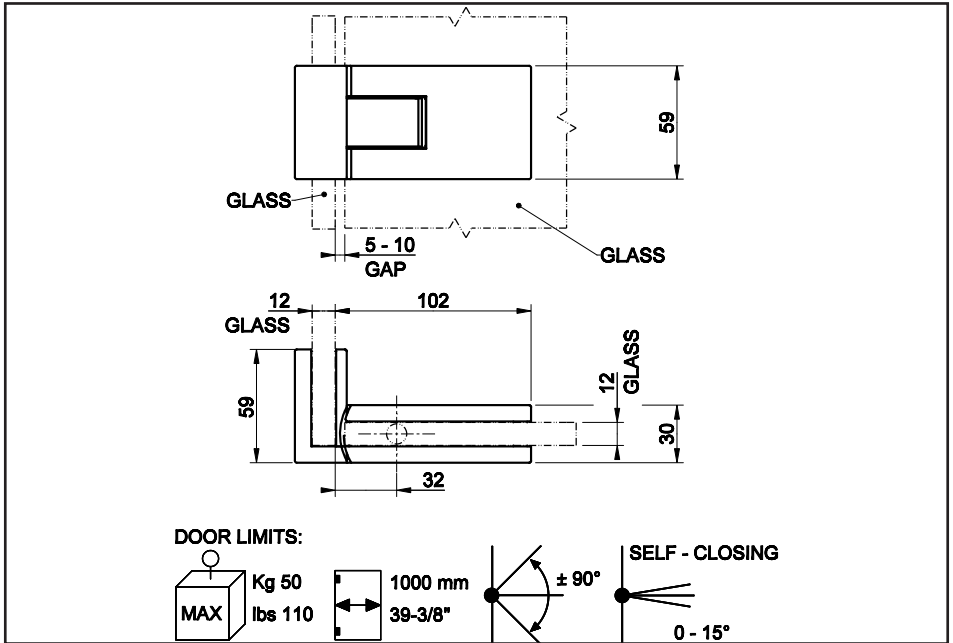

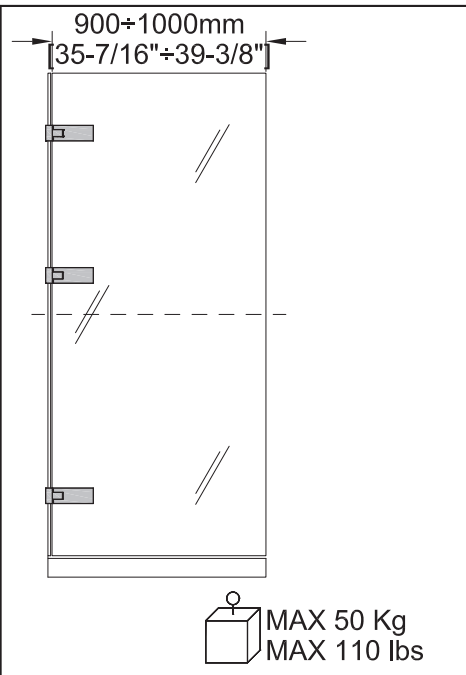
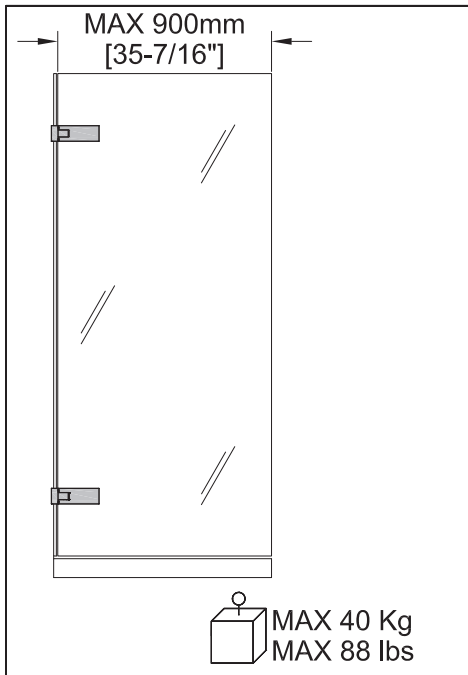

**GLASS CUT
DOWNLOAD**

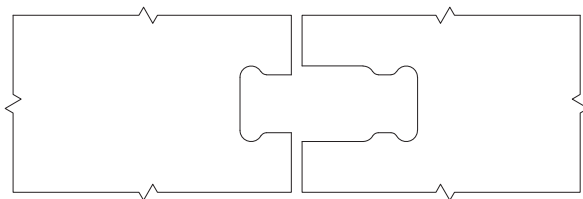
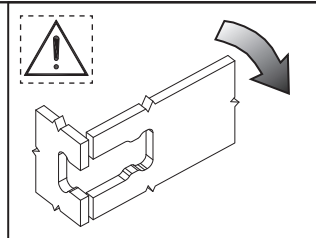

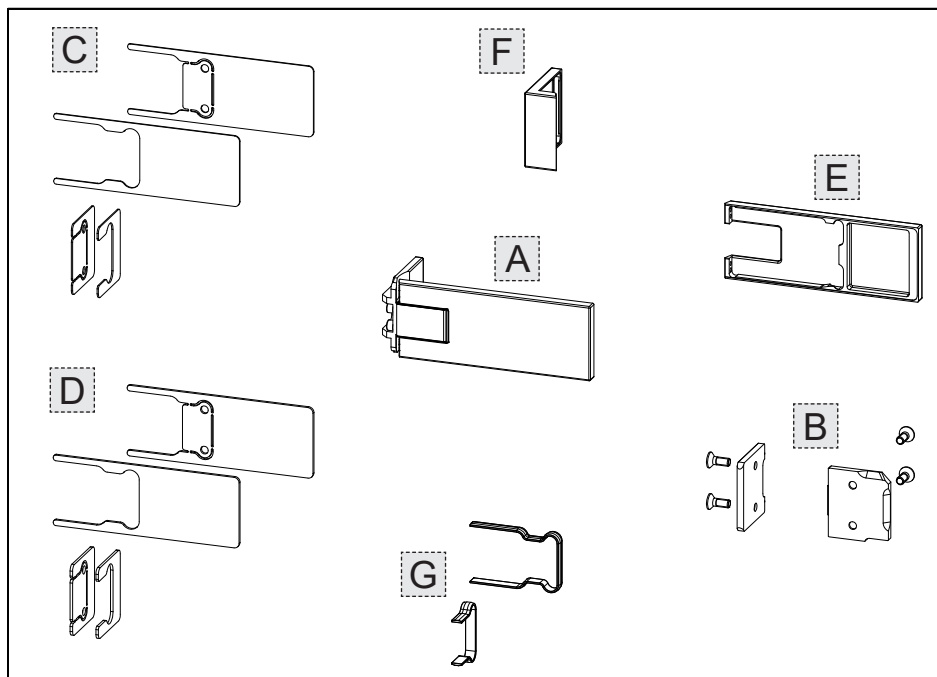

Contenuto della confezione:

- A - Corpo cerniera
- B - Set di fissaggio
- C - Kit guarnizioni - 1mm[1/32"] (4x)
- D - Kit guarnizioni - 2mm[3/32"] (4x)
- E - Cover interna
- F - Cover esterna
- G - Guarnizione sagomata

Package content:

- A - Hinge body
- B - Fastening set
- C - Seals kit - 1mm[1/32"] (4x)
- D - Seals kit - 2mm[3/32"] (4x)
- E - Internal cover
- F - External cover
- G - Shaped gasket

Contenu de l'emballage:

- A - Corps charnière
- B - Set de fixation
- C - Kit joints - 1mm[1/32"] (4x)
- D - Kit joints - 2mm[3/32"] (4x)
- E - Cache intérieur
- F - Cache extérieur
- G - Joint profilé

Inhalt der Verpackung:

- A - Scharniergehäuse
- B - Befestigungsset
- C - Bausatz der Dichtungen - 1mm[1/32"] (4x)
- D - Bausatz der Dichtungen - 2mm[3/32"] (4x)
- E - Innere Abdeckung
- F - Äußere Abdeckung
- G - Formdichtung

Contenido de la caja:

- A - Cuerpo de la bisagra
- B - Juego de fijación
- C - Juego juntas - 1mm[1/32"] (4x)
- D - Juego juntas - 2mm[3/32"] (4x)
- E - Cubierta interna
- F - Cubierta externa
- G - Junta moldeada

Содержимое упаковки:

- A - Петля дверцы
- B - Комплект крепления
- C - Набор уплотнений - 1mm[1/32"] (4x)
- D - Набор уплотнений - 2mm[3/32"] (4x)
- E - Внутренняя крышка
- F - Наружная крышка
- G - Фигурный уплотнитель

Περιεχόμενο συσκευασίας:

- A - Σώμα μεντεσέ
- B - Σετ στερέωσης
- C - Κιτ παρεμβυσμάτων - 1mm[1/32"] (4x)
- D - Κιτ παρεμβυσμάτων - 2mm[3/32"] (4x)
- E - Εσωτερικό κάλυμμα
- F - Εξωτερικό κάλυμμα
- G - Μορφοποιημένο παρέμβυσμα

包裝內含:

- A - 合頁主件
- B - 固定套件
- C - 墊圈 - 1mm[1/32"] (4x)
- D - 墊圈 - 2mm[3/32"] (4x)
- E - 內蓋
- F - 左側內蓋
- G - 外蓋

Fig. 1

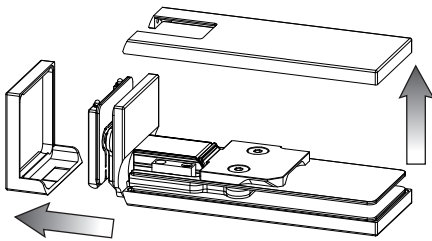

Fig. 2

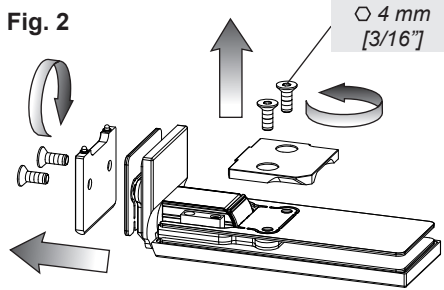

Fig. 3

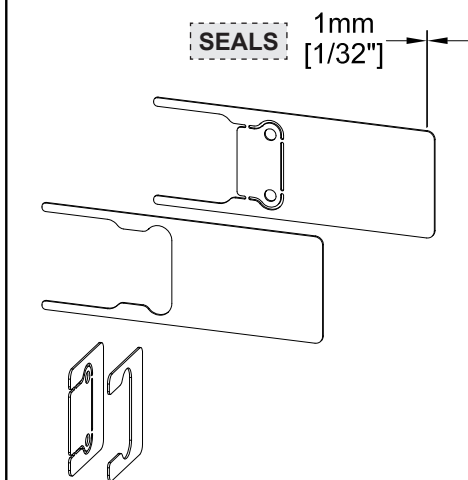
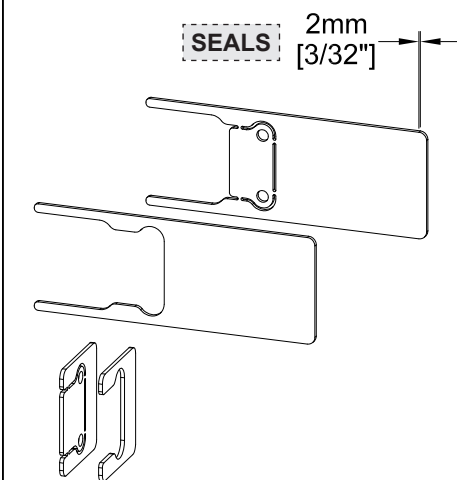
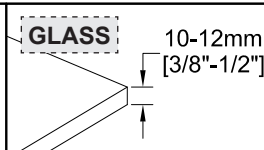
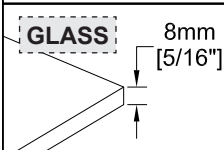
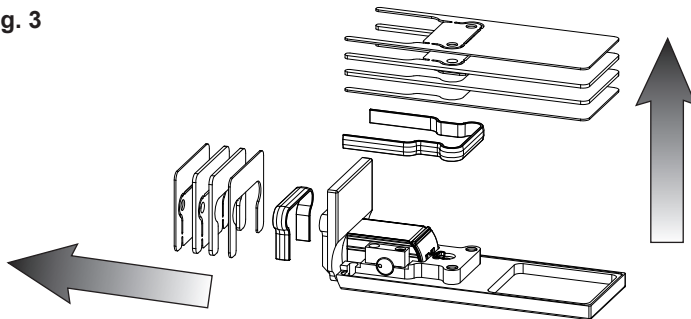

Fig. 4

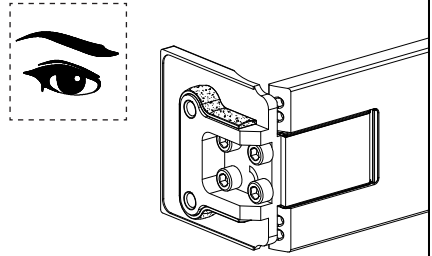
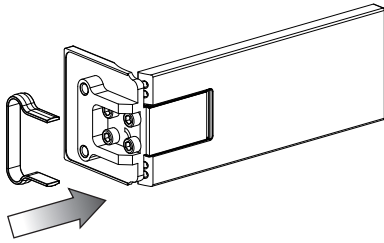

Fig. 5

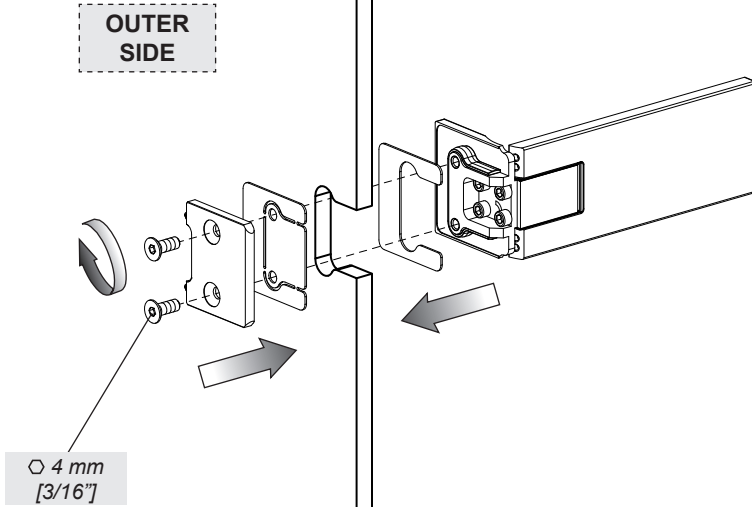

Fig. 6

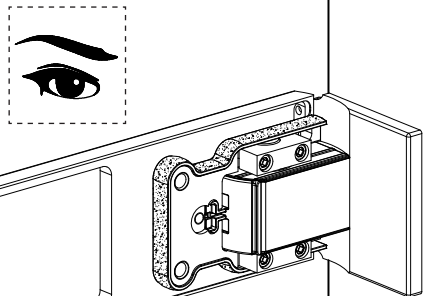
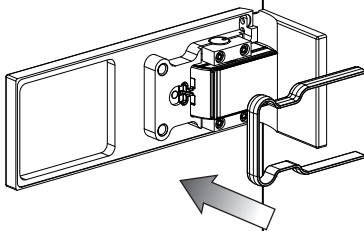

Fig. 7

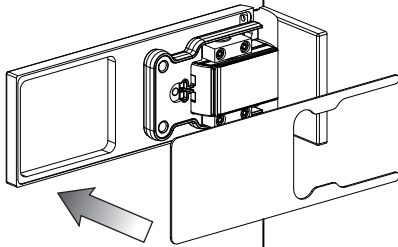

Fig. 8

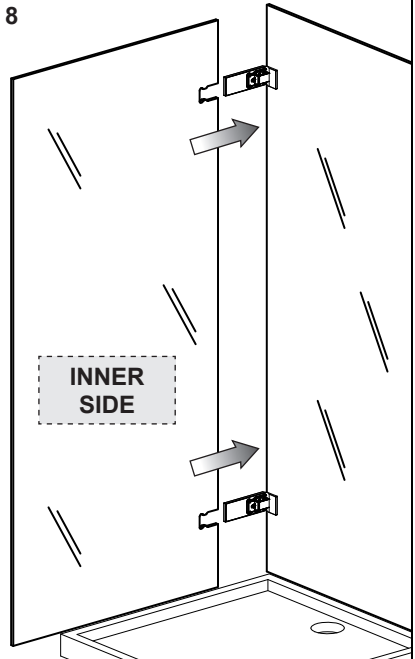

Fig. 9

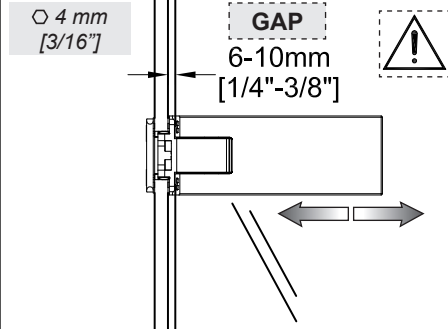
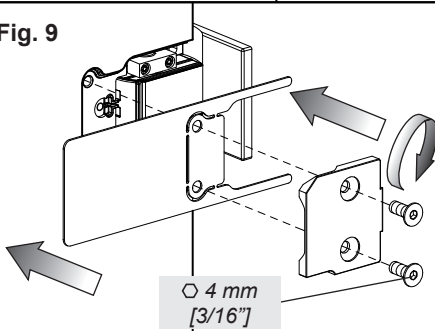

Fig. 10

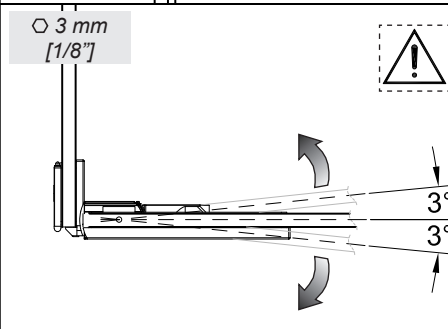
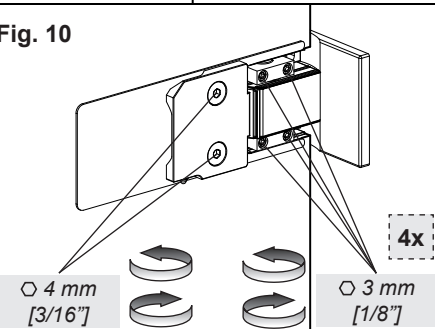

Fig. 11

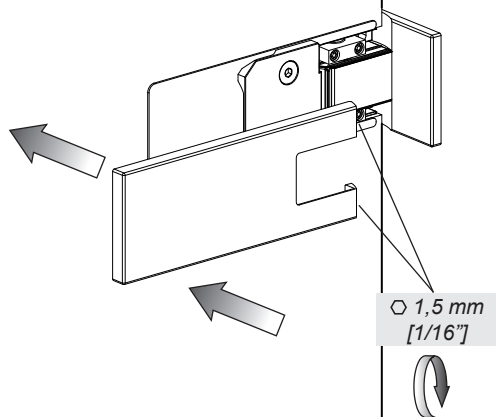

Fig. 12

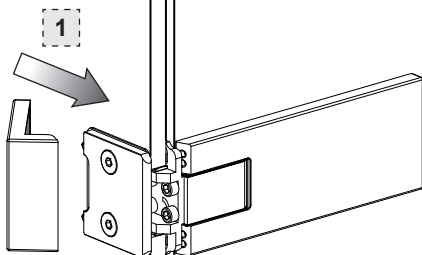
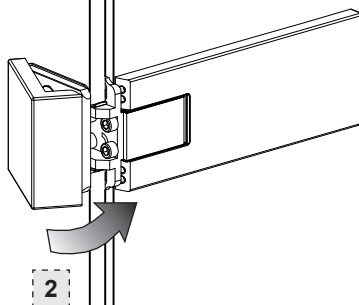

Fig. 13





MANUTENZIONE

- Nel caso sia necessario sostituire uno o più componenti, contattare un rivenditore autorizzato o visitare il sito WWW.GESSI.COM
- Affidare la manutenzione del prodotto a personale qualificato

MAINTENANCE

- Should it be necessary to replace one or more components, contact an authorized retailer or visit WWW.GESSI.COM
- Product maintenance should be made only by qualified staff

ENTRETIEN

- S'il est nécessaire de remplacer un ou plusieurs composants, contacter un centre autorisé ou visiter le site WWW.GESSI.COM
- L'entretien du produit ne doit être effectué que par du personnel qualifié

WARTUNG

- Falls das Auswechseln von einem oder mehreren Bestandteilen erforderlich wird, kontaktieren Sie bitte einen autorisierten Fachhandel oder besuchen Sie unsere Website unter WWW.GESSI.COM
- Die Instandhaltung des Produktes sollte nur qualifiziertem Personal anvertraut werden.

MANUTENCIÓN

- En el caso de que sea necesario remplazar uno o más componentes, contacten con un revendedor autorizado o visiten el sitio WWW.GESSI.COM
- Encarguen sólo a personal calificado para el mantenimiento del producto

ОБСЛУЖИВАНИЕ

- В случае если будет необходимо заменить один или несколько компонентов, обратитесь к авторизованному дистрибьютору или посетите веб-сайт WWW.GESSI.COM
- Обслуживание изделия должен выполнить квалифицированный персонал.

ΣΥΝΤΗΡΗΣΗ

- Σε περίπτωση που είναι απαραίτητο να αντικαταστήσετε ένα ή περισσότερα εξαρτήματα, επικοινωνήστε με ένα εξουσιοδοτημένο κατάστημα πώλησης ή επισκεφθείτε τον ιστότοπο WWW.GESSI.COM
- Εμπιστευθείτε τη συντήρηση του προϊόντος σε διαπιστευμένο προσωπικό

保养

- 若需替换一个或者多个部件，请联系授权分销商或浏览WWW.GESSI.COM网站
- 请让合格人士负责产品保养工作

